

HV2 Precleaner with V-Tips

High Efficiency Tungsten-Carbide Precleaner

The Flexco HV2 Precleaner with V-Tips is designed to be positioned on the head pulley and to remove the bulk of the carryback from the belt. Utilizing a new cushion design, the HV2 improves on the H-Type which has proven performance over 20 years as the most efficient pre-cleaner in material handling applications such as coal, iron ore, bauxite and hard rock mining with vulcanized belts.



Quick Mount Tensioner (QMT)
allows the blade tension to be visually inspected

Durable tungsten carbide tips

152mm (6") segmented blades ensure proper wear throughout the life of the blade

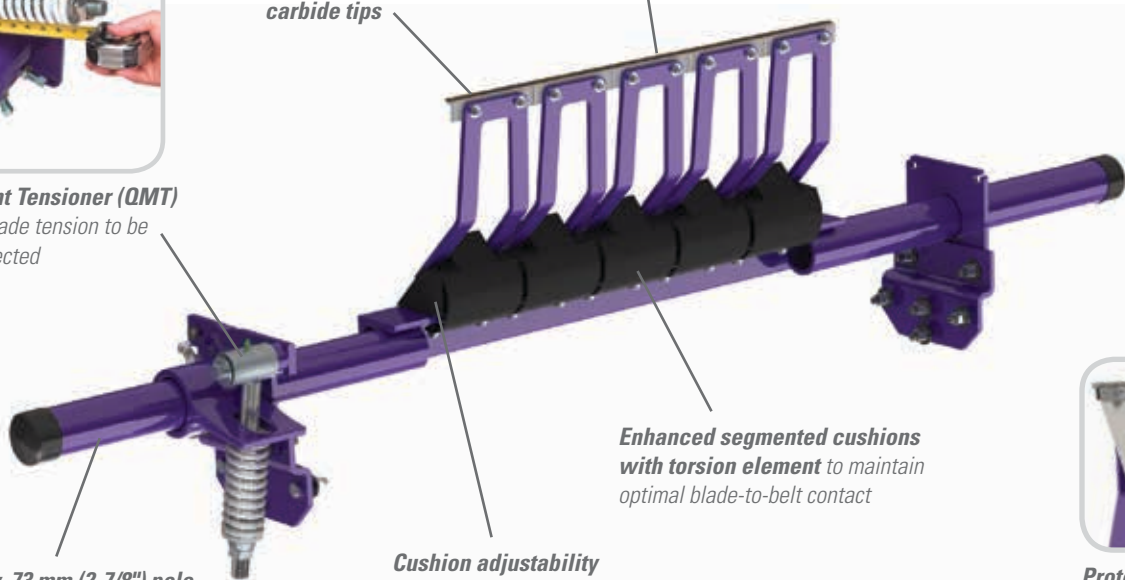

Heavy-duty, 73 mm (2-7/8") pole
ensures durability for those tough applications

Cushion adjustability
so no shimming is required

Enhanced segmented cushions with torsion element to maintain optimal blade-to-belt contact



Protected V-Tip Option

Features and Benefits

- **Works with vulcanized belts.** The tungsten carbide tips allow for maximum cleaning efficiency and superior wear characteristics. Also available with protected tips for abrasive applications.
- **Complete cleaning system.** When teamed with a secondary cleaner, it makes up a system that delivers maximum cleaning power for the most abusive conveyor applications.
- **Made for mining conveyors.** Made from heavy-duty steel with corrosion-resistant powder coating, the HV2 is available in sizes for belt widths from 450 to 1800mm" (18" to 72"). Additional sizes are available upon request.
- **Optimal positioning.** Blade contact on the pulley is 15° below the horizontal centerline. This keeps the blades out of the discharge path and protects them from rocks, large lumps and other debris.
- **150mm (6") Tips** for better conformity to the belt.
- **Incorporates torsion element design** and cushion adjustability so no shimming is required to ensure proper blade to belt contact.

HV2 Precleaner with V-Tips

Specifications and Guidelines

Maximum Belt Speed

7.6 m/s (1500 FPM)

Temperature Rating

-35° C to 82° C F (-30° F to 180°)

Minimum Pulley Diameter

250mm (10")

Usable Blade Wear Length

9mm (3/8")

Blade Material

Tungsten carbide (for vulcanized belts only)

Available for Belt Widths

450 to 1800mm (18" to 72")

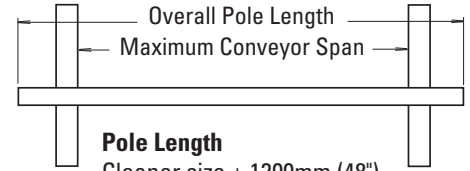

Pole Length
Cleaner size + 1200mm (48")

Maximum Conveyor Span
Cleaner size + 950mm (38")

Ordering Information

HV2 Precleaner with V-Tips*				
Belt Width		Suspension Arm Size	Ordering Number	Item Code
mm	in.			
450	18	SS	HV2-18SS	79323
450	18	S	HV2-18S	79324
450	18	M	HV2-18M	79325
600	24	SS	HV2-24SS	79326
600	24	S	HV2-24S	79327
600	24	M	HV2-24M	79328
750	30	SS	HV2-30SS	79329
750	30	S	HV2-30S	79330
750	30	M	HV2-30M	79331
900	36	SS	HV2-36SS	79332
900	36	S	HV2-36S	79333
900	36	M	HV2-36M	79334
900	36	L	HV2-36L	79335
1050	42	SS	HV2-42SS	79336
1050	42	S	HV2-42S	79337
1050	42	M	HV2-42M	79338
1050	42	L	HV2-42L	79339
1050	42	LL	HV2-42LL	79340
1200	48	SS	HV2-48SS	79341
1200	48	S	HV2-48S	79342
1200	48	M	HV2-48M	79343
1200	48	L	HV2-48L	79344
1200	48	LL	HV2-48LL	79345
1350	54	S	HV2-54S	79346
1350	54	M	HV2-54M	79347
1350	54	L	HV2-54L	79348
1350	54	LL	HV2-54LL	79349
1500	60	S	HV2-60S	79350
1500	60	M	HV2-60M	79351
1500	60	L	HV2-60L	79352
1500	60	LL	HV2-60LL	79353
1800	72	S	HV2-72S	79354
1800	72	M	HV2-72M	79355
1800	72	L	HV2-72L	79356
1800	72	LL	HV2-72LL	79357

*NOTE: V-Tips can be used ONLY on vulcanized belts.

Suspension arm size is determined by head pulley diameter - see chart.

Additional sizes available upon request.

Lead time: 1 working day

Suspension Arm Size		
Head Pulley Diameter + Belt & Lagging		Suspension Arm Size
mm	in.	
250-475	10 - 19	SS
500-775	20 - 31	S
800-975	32 - 39	M
1000-1175	40 - 47	L
1200-1675	48 - 67	LL

Replacement V-Tips

Ordering Number	Item Code
HV2T-S/S	79367

Lead time: 1 working day

Replacement Protected V-Tips

Ordering Number	Item Code
HV2PT	79368

Lead time: 1 working day

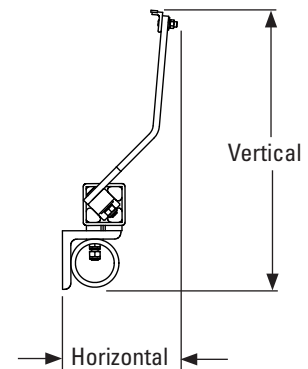

Horizontal Clearance Required
210mm (8-1/4")

Vertical Clearance Required

SS: 320mm (12-5/8")

S: 390mm (15-3/8")

M: 416mm (16-5/8")

L: 445mm (17-1/2")

LL: 511mm (20-1/8")

Authorized Distributor:



240 Macpherson Road • #02-01 • Singapore 348574
Tel: +65-6484-1533 • Fax: +65-6484-1531 • E-mail: asiasales@flexco.com

Visit www.flexco.com for other Flexco locations and products.

©2019 Flexible Steel Lacing Company. 07/25/19. For reorder: X4013